

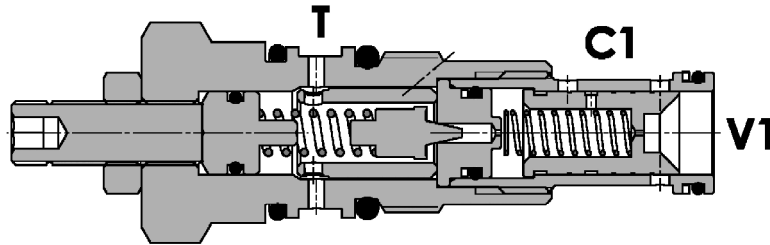

Valvola di sequenza pilotata, taratura regolabile, a cursore
Sequence valve pilot operated, spool type

Rev.03-2022/05

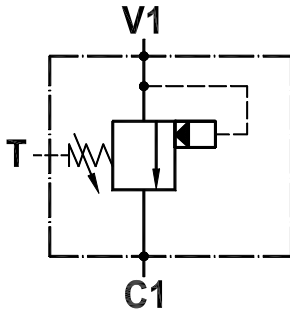

SPECIFICHE TECNICHE

Materiali: cartuccia in acciaio zincato, parti interne in acciaio trattato termicamente.

Portata: 150 l/min

Taratura max.: 350 bar

Regolazione pressione: mediante vite

Coppia di serraggio in cavità: 60-70 Nm

Cavità: 36241 (vedere sezione X)

Peso cartuccia: 0,300 Kg

TECHNICAL SPECIFICATIONS

Materials: cartridge in steel zinc plated, internal parts are in hardened steel.

Rated flow: 150 l/min

Max. setting: 350 bar

Adjustment means: leakproof screw

Installation torque: 60-70 Nm

Cavity: 36241 (see section X)

Cartridge weight: 0,300 Kg

DIAGRAMMA PERDITE DI CARICO PRESSURE DROP CURVES

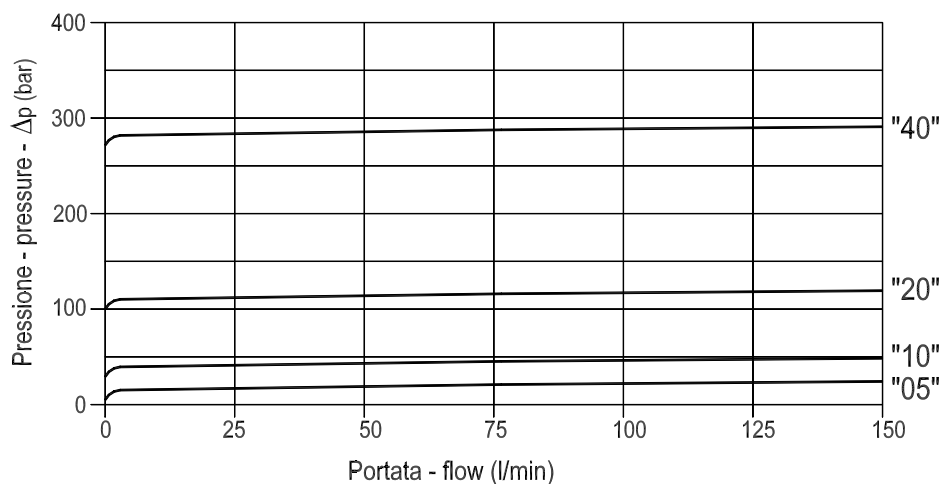



Valvola di sequenza pilotata, taratura regolabile, a cursore
Sequence valve pilot operated, spool type

Rev.03-2022/05

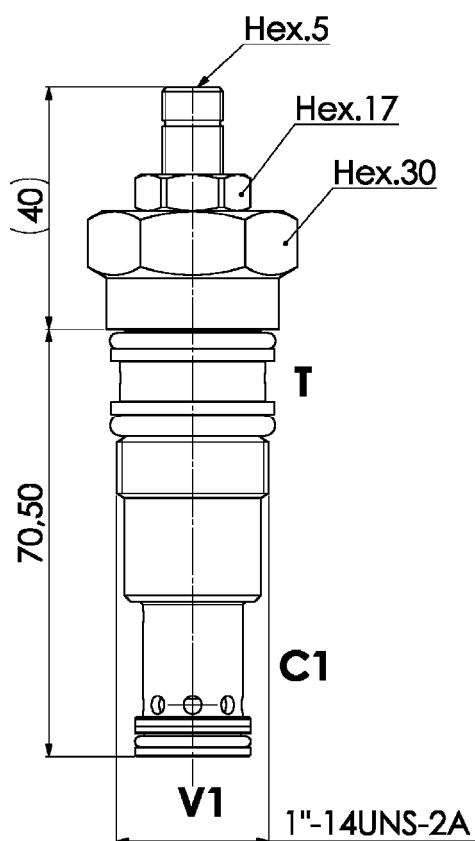

MOLLE - SPRINGS				*
Codice Code	Campo taratura min.-max. bar Adjustable pressure range bar	Increment. press. bar/giro vite Pressure increase bar/tum	Taratura standard bar Standard setting bar	Colore Color
05	5 - 45	7.5	5	Neutro Neutral
10	10 - 120	26	10	Bianco White
20	15 - 250	55	15	Giallo Yellow
35	20 - 350	120	20	Verde Green

REGOLAZIONI - ADJUSTEMENTS		*
Codice Code	Tipo - Type	
P	Vite esterna con esagono incassato Leakproof hex. socket screw	
R	Volantino e dado Handknob and locknut	

ESEMPIO DI ORDINAZIONE - ORDERING CODE EXAMPLE

F P S Q U P **P** **1 5 0** **C** **P** **1 0**

* P/R:
Regolazioni - Adjustements

%05+ / %10+ / %20+ / %35+
Campi di taratura pressione *
Adjustable pressure range